

# FL91BR.7\*\* - Kompressionsverschluss - Rechts

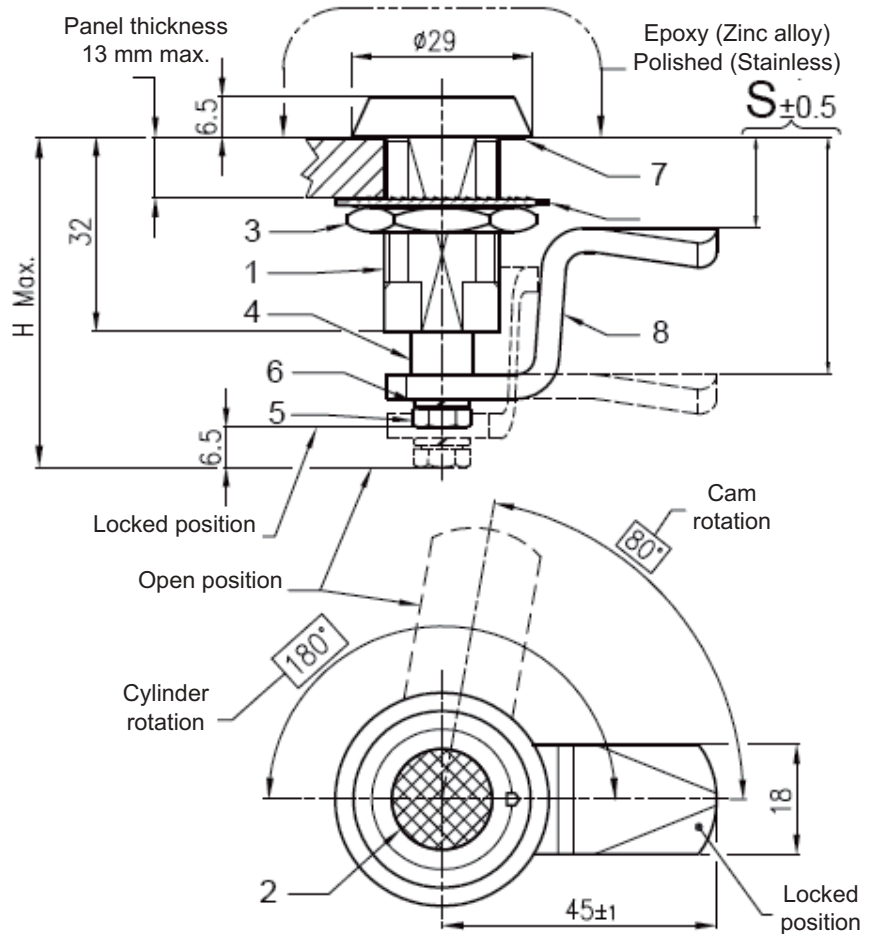

Fixing hole size

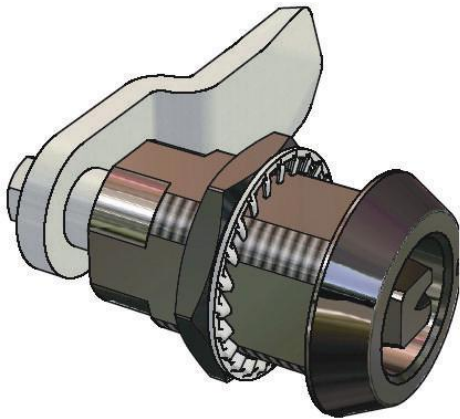
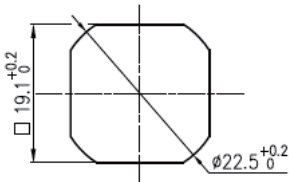

Insert \* head style "code" and  $\phi\phi$  material "code" into lock part number (see page 34)

Ref	Part description	ZINC ALLOY CHROME (BC) Material - Finishing	STAINLESS STEEL (BP) Material - Finishing	ZINC ALLOY EPOXY (BK) Material - Finishing
1	Housing	Zinc alloy - Bright chrome	AISI304 - polished	Zinc alloy - Epoxy black
2	Cylinder	9SMnPb36 - Bright chrome	AISI303 - polished	9SMnPb36 - Epoxy black
3	Nut M22X1,5 Ch. 27	Steel - White zinc Cr6 free	AISI303	Steel - White zinc Cr6 free
4	Rotation stud	9SMnPb36 - White zinc	AISI303	9SMnPb36 - White zinc
5	Screw	AISI304	AISI304	AISI304
6	Washer	AISI304	AISI304	AISI304
7	Protection washer	NBR	NBR	NBR
8	Cam	Steel - White zinc Cr6 free	AISI304 - polished	Steel - White zinc Cr6 free