

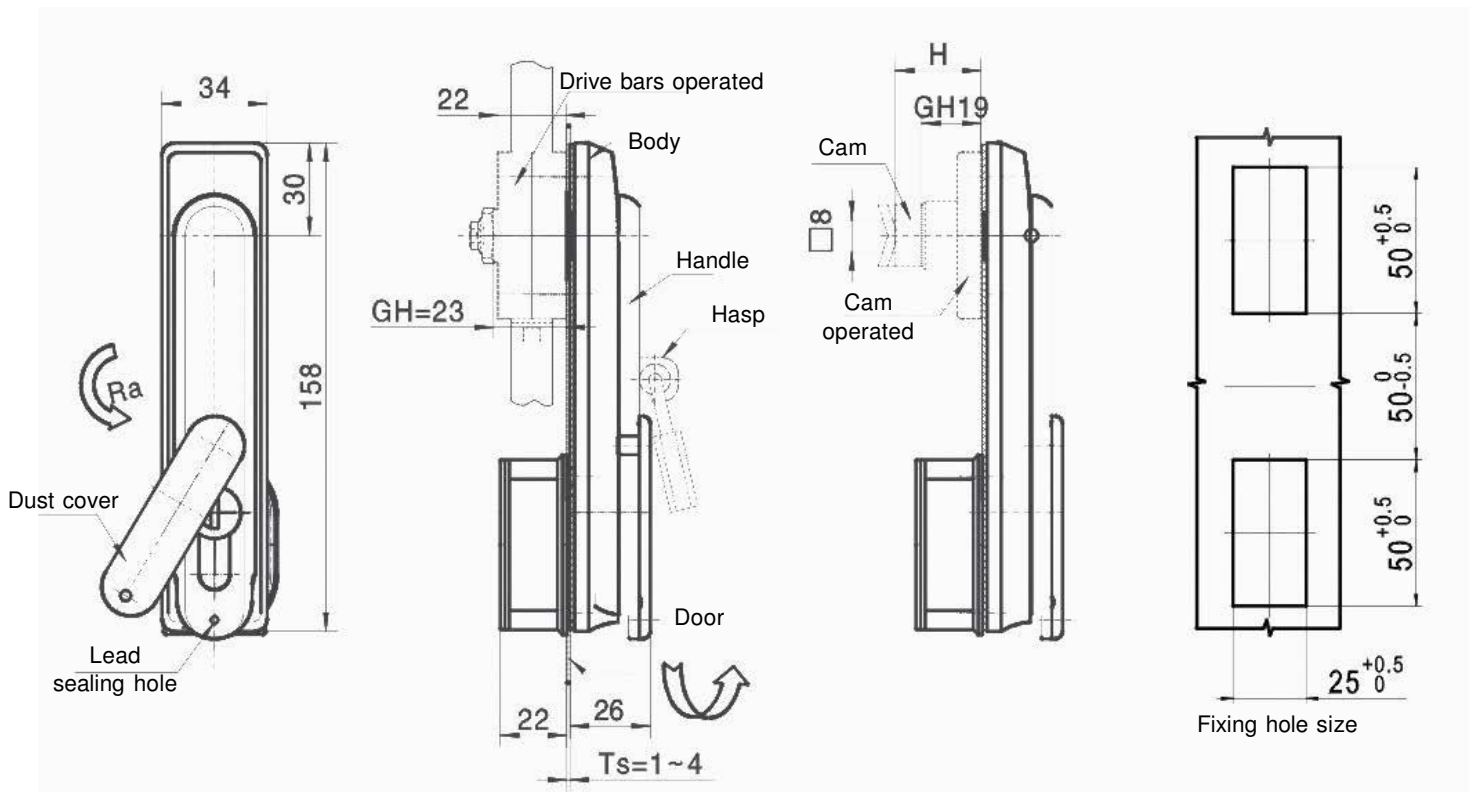

FH840 - Schwenkgriff - Stangenschloss



Options: Cam operated Mb9; see page 14
 Drive bars operated Mb0; see page 14

Handle part number	Description
FH840.1	Drive bars, with Mb01
FH840.1.2	Drive bars, with Mb02
FH840.2	Cam

Ref	Part description	Material - Finishing
1	Body and Handle	Zinc alloy - Black powder coated
2	Cam	Steel - White zinc Cr6 free
3	Key-lock cylinder	Zinc alloy - Bright chrome