

# 5\*1197 - einstellbarer Drehriegel, Zinkdruckguss

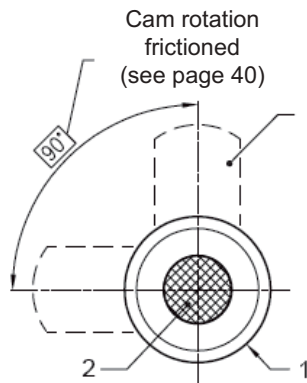

Cam on request  
(see page 38)

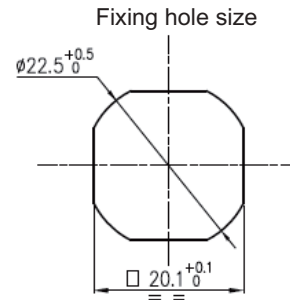
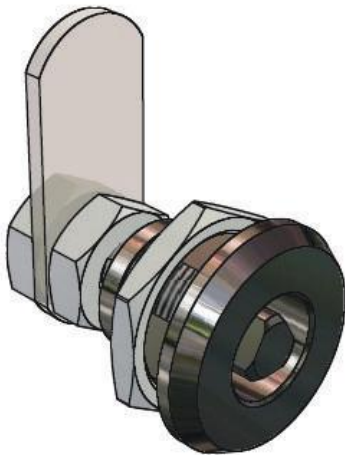
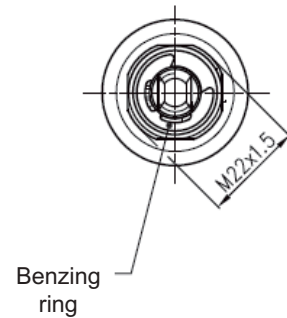
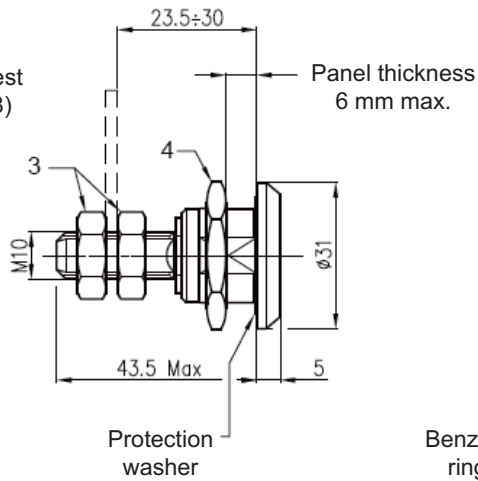

Triangle 8 mm

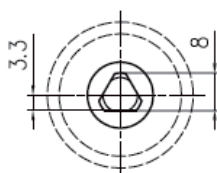

Code: B

Slotted recess



Code: D

P3 pin

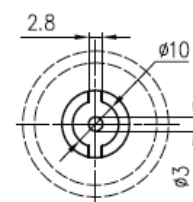

Code: P

Insert \* head style "code" into lock part number.

Lock Part Number (cam excluded)
5*1197DZWZJ5TW

Ref	Part description	Material - Finishing
1	Housing	Zinc alloy - Bright chrome
2	Cylinder	Zinc alloy - Bright chrome
3	Nut M10 low (2)	Steel - White zinc Cr6 free
4	Nut M22X1,5 Ch. 27	Steel - White zinc Cr6 free