

C400.537 - Sicherheitsdrehriegelverschluss

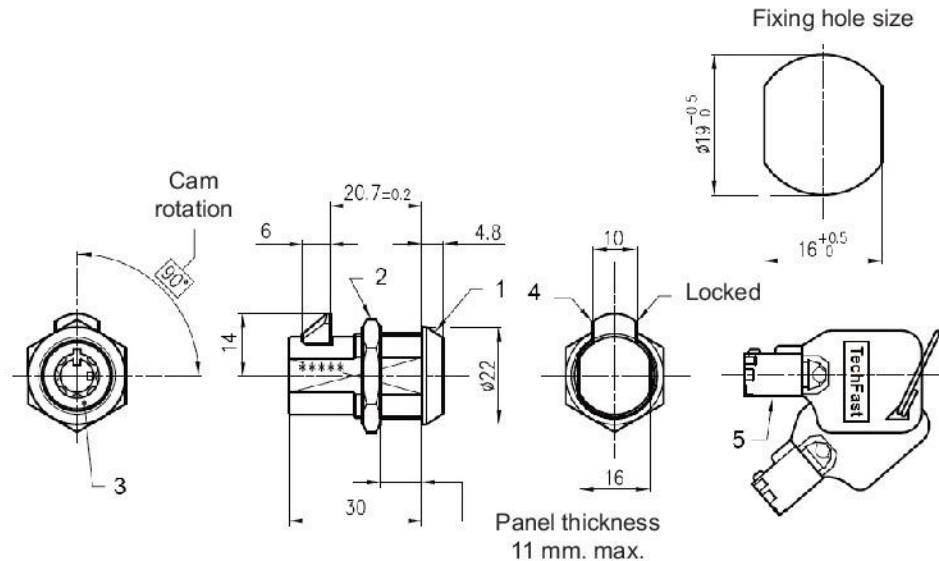
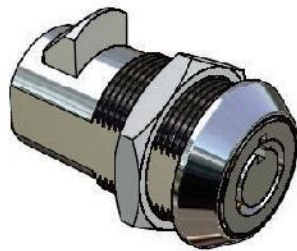

Lock Part Number
C400.537

Ref	Part description	Material - Finishing
1	Body 3/4" - 27	Zinc alloy - Bright chrome
2	Nut 3/4" - 27	Zinc alloy - White zinc Cr6 free
3	Cylinder	Zinc alloy - Bright chrome
4	Locking pin	Zinc alloy - Nickel
5	Key, 50.000 different key codes (2)	1 LFNHO SODVWL 2 HG