

FH714 - Drehriegel, Zinkdruckguss / Plastik / Edelstahl

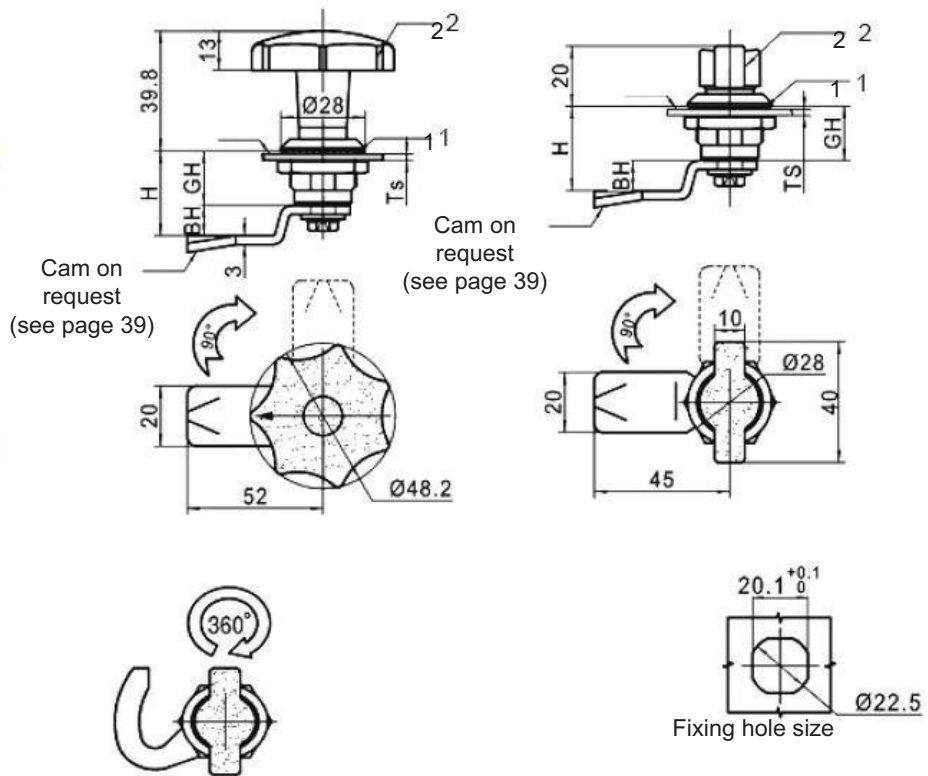

Insert $\phi\phi$ material code into lock part number.
© Standard version - for other version minimum order quantity 1.000 pcs.

Lock Part Number Knob	GH	Ts max.
FH714.1.1 $\phi\phi$ ©	18	8
FH714.1.2 $\phi\phi$	28	22
FH714.1.3 $\phi\phi$	38	28
FH714.1.4 $\phi\phi$	62	52

Ref	Part description	ZINC ALLOY/PLASTIC (BK) © Material - Finishing	PLASTIC/PLASTIC (PN) Material - Finishing
1	Housing	Zinc alloy - Black painted	Plastic, black
2	Knob	Plastic, black	Plastic, black
3	Cam	Steel - White zinc Cr6 free	Steel - White zinc Cr6 free

Insert $\phi\phi$ material code into lock part number.

Lock Part Number Central wing	GH	Ts max.
FH714.2.1 $\phi\phi$ ©	18	8
FH714.2.2 $\phi\phi$	28	22
FH714.2.3 $\phi\phi$	38	28
FH714.2.4 $\phi\phi$	62	52

Ref	Part description	ZINC ALLOY/PLASTIC (BK) © Material - Finishing	PLASTIC/PLASTIC (PN) Material - Finishing
1	Housing	Zinc alloy - Black painted	Plastic, black
2	Central wing	Plastic, black	Plastic, black
3	Cam	Steel - White zinc Cr6 free	Steel - White zinc Cr6 free